

3730

3730 SERIES



3730A

BEACONS

LIGHTBARS/
MINIBARS

SAFETY
DIRECTOR™

LED DIRECTIONAL
LIGHTS

LIGHTING
SYSTEMS

BACK-UP
ALARMS

CAMERA
SYSTEMS

SAE Class II LED Light Head Surface Mount

This compact and versatile surface-mount LED directional light is ideal for applications requiring high intensity output, low-current draw and maintenance-free operation. These premium LED heads feature a clear acrylic lens optic with LEDs that illuminate in the color of your choice. Warning capability can be customized by selecting from 14 different flash patterns (via a trigger wire) and synchronizing multiple heads simultaneously or alternately. The coated aluminum base and urethane-sealed electronics protect the unit against the environment, making this one of the most rugged LED products available. And, it's covered by a full 5-year warranty.

Models

PART NO.	VOLTAGE	AMPS	MOUNT
3730X	12-24	0.2	Surface

Replace X in part number with desired color: A=amber, B=blue, C=clear, R=red

Features and Benefits

- Rugged die-cast coated aluminum housing with urethane-encapsulated electronics
- 14 flash patterns, including 3 integral alternating flash modes
- Discrete units are colorless when not illuminated
- Multiple units can be synchronized
- LEDs offer a long, maintenance-free service life
- SAE J845 Class II
- CE, e
- IP Rating 67
- Temperature Range: -22°F to +122°F (-30°C to +50°C)
- Warranty: 5 years

Accessories

UNIVERSAL
A3730BKT



TRUNK
A3730TNK



DECK
A3730DCK



WINDOW
A3730WIN



LICENSE
A3730LIC

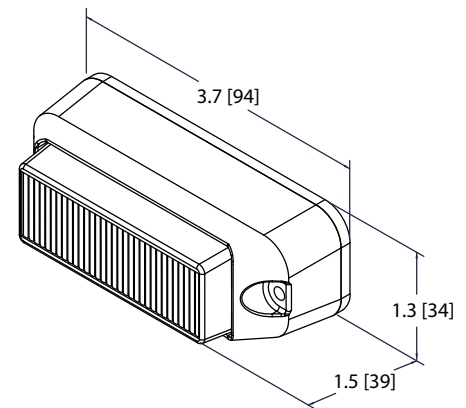

Flash Patterns (14)

Steady Burn	Quint
Single	Pulse8
Fast Single	Constant Flicker
Double	Integral Double Alternating
Fast Double	Integral Fast Double Alternating
Triple	Integral Quad Alternating
Quad	Cycle

ECCO®

833 West Diamond Street
Boise, Idaho 83705

T: 800-635-5900 or 208-395-8000
F: 800-688-3226 or 208-395-8190
www.eccolink.com

A DIVISION OF
 ECCO
GROUP