

# 3900

## 3900 SERIES

3945

3965



BEACONS

LIGHTBARS/  
MINIBARS

SAFETY  
DIRECTOR™

LED DIRECTIONAL  
LIGHTS

LIGHTING  
SYSTEMS

BACK-UP  
ALARMS

CAMERA  
SYSTEMS

## SAE Class I LED Light Heads Grommet Mount

These independent LED directional lights offer long-life, low maintenance operation with no moving parts or bulbs/flashtubes to break or replace. Simply fit in standard oval and round rear lighting grommets. 8 flash patterns.

### Models

PART NO.	VOLTAGE	AMPS	SHAPE
3945X	12	0.2	Round
3965X	12	0.2	Oval

Replace X in part number with desired color: A=amber, B=Blue, C=Clear, R=red

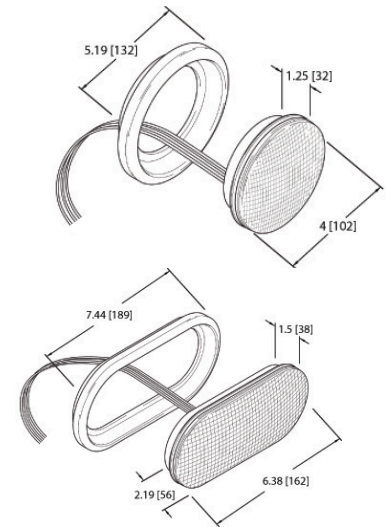

### Features and Benefits

- High output LEDs offer low maintenance, long life and low current consumption
- Ultrasonically sealed housing
- Fits in standard oval or round rear lighting grommet (included)
- Vibration and shock resistant construction
- Single, Slow Single, Fast Single, Double, Fast Double, Quad, Quint and Warp flash patterns
- SAE J595 Class I
- Temperature Range: -22°F to +122°F (-30°C to +50°C)
- Warranty: 1 year

### 3900 Series Accessories

Grommets: Round - R2140GR  
Oval - R2160GO

Mounting Boxes: Round - A9894  
Oval - A9895

# ECCO®

833 West Diamond Street  
Boise, Idaho 83705

T: 800-635-5900 or 208-395-8000  
F: 800-688-3226 or 208-395-8190  
www.eccolink.com

A DIVISION OF  
 ECCO  
GROUP