



## 9014 SERIES Surface Mount / Concealed Warning LEDs

The 9014 is a high intensity directional LED warning light specifically designed for vehicle headlight and tail light applications. In addition, the 9014 can also be surface mounted to the vehicle exterior using the included mounting bezel. Featuring six LEDs that provide exceptional warning. A sealed in-line driver module eliminates the need for a remote power supply. Also features multiple flash patterns and synchronization capability with other Hide-A-LEDs and the 3510. Additional benefits of LED technology include low current draw and a long maintenance free service life.

### Models

PART NO.	VDC	AMPS	FLASH PATTERNS	MULTI COLOR	ILLUMINATION COLOR(S)	MOUNT
9014X	12-24	0.6-1.25	16	No	Choose Color	Surface or 1" Hole

Replace X in part number with desired LED color: A = amber, B = blue, C = clear, R = red

### Features and Benefits

- Six 1-watt high-intensity LEDs provide exceptional warning
- Head/tail light or surface mountable using included bezel
- 16 flash patterns including single, double, triple, quad, deci and cycle all
- Multiple heads are synchronizable (simultaneous or alternating operation)
- Colorless when not illuminated
- In-line waterproof driver module eliminates need for a remote power supply
- UV stabilized polycarbonate lens, nickel-plated housing and 9' cable
- Warranty: 2 years

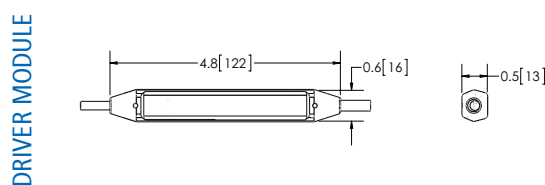
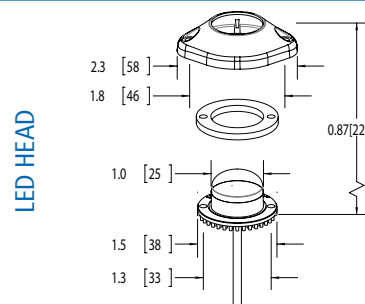
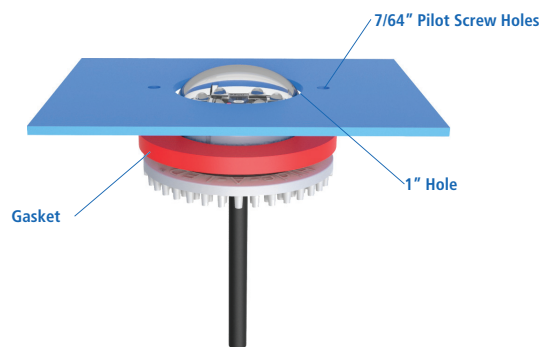

### Solid Color:

- 200+ Lumens (Amber)
- 100+ Lumens (Blue)
- 460+ Lumens (Clear)
- 200+ Lumens (Red)

### Flash Patterns

Flash patterns are selected by touching the blue wire momentarily to power; the LED head will cycle through the available patterns.

STANDARD PATTERNS			
#	PATTERNS	FREQUENCY	DESCRIPTION
1	Quad Flash	1.25 Hz	75 Quad FPM
2	Double Flash	1.25 Hz	75 Double FPM
3	Triple Flash	1.25 Hz	92.3 Triple FPM
4	Deciblast	1.25 Hz	85.5 Deci FPM
5	Single Flash	1.25 Hz	75 Single FPM
6	Mega Flash	1.25 Hz	114 Single FPM
7	Triple+Burst	1.25 Hz	82.5 Triple + Burst FPM
8	Steady On		Steady On

CYCLE PATTERNS			
#	PATTERNS	FREQUENCY	DESCRIPTION
9	Cycle All		Cycle through patterns 1 to 7
10	Double-Triple + Burst		2 Double, 2 Triple + Burst cycle
11	Cycle Classic		1 Double, 1 Quad, 2 Mega cycle
12	Quad-Mega		3 Quad, 4 Mega cycle
13	Single-Quad		2 Single, 2 Quad cycle
14	DeciBlast-Quad		2 DeciBlast, 2 Quad cycle
15	Single-Triple-DeciBlast		2 Single, 2 Triple, 2 DeciBlast cycle
16	Mega-Triple+Burst		1 Mega, 1 Triple+Burst cycle

### Alternating/Simultaneous Flash Selection

The yellow wire on each LED head is used to determine alternating or simultaneous operation with other heads in the system that are connected using the blue wire. The yellow wire has no function when 'Steady On' flash pattern is selected.

- Connect the YELLOW wire to either POWER or GROUND
- Heads with YELLOW connected to POWER fire SIMULTANEOUSLY with other heads connected to POWER
- Heads with YELLOW connected to GROUND fire SIMULTANEOUSLY with other heads connected to GROUND
- Heads with YELLOW connected to POWER fire ALTERNATELY with other heads connected to GROUND

Note: The blue wires of all LED heads must be connected together for the alternating/simultaneous function to operate.

### Wiring Diagram

The diagram below shows a typical installation of 4 HIDE-A-LEDs using an on/off switch. The left and right-side heads are configured to flash alternately with each other using the blue wire to connect the two with the yellow wire on one connected to ground and the yellow wire on the other connected to power.

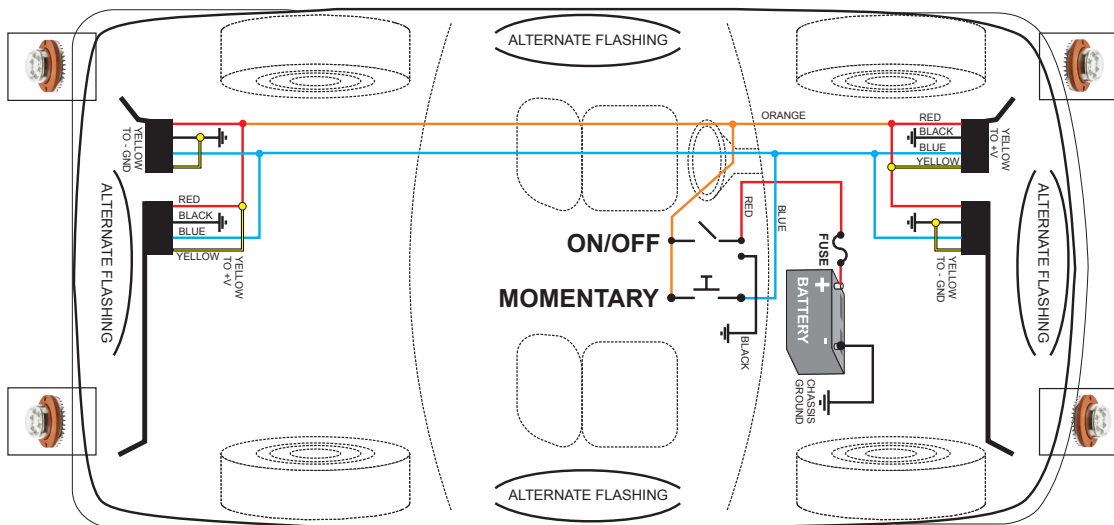

The front and rear heads are configured to flash independently of each other. In order to have the front and rear heads flash in synchronization, the blue wires from all units must be connected. The yellow wire can then be used to determine either alternate or simultaneous flash between each unit in the system by connecting to either power or ground.